

SolCool 100% Return - Standard Install

The patented SolCool Hybrid Air Conditioning Unit with the solar option is a low power consumption alternative to conventional air conditioning and more. The 120/12 volt system utilizing eight cubic feet of chiller and four square feet of dry coil technology is less inclined to use raw power and more inclined to use its install environment to solve cooling situations. With its use of a half horsepower, low temperature compressor, ducted filtered return and direct supply, back-up DC battery and solar, DC lighting and ceiling fan options the SolCool is more than an elegant solution to air conditioning, back up air conditioning and air cleaning requirements.

The information below is intended to provide prospective distributors and resellers with an overview of SolCool pre-check and a simple 100% return installation configuration. If you are ducting the return consult; info@solcool.net for technical support.

Prior to beginning the install, plug the SolCool, (SC024HH) into a standard 120 volt wall outlet with a minimum of a 15 Amp circuit to activate the compressor. After approximately five minutes check the temperatures of the water reservoir cooling manifold behind the large rear service panel at the bottom of the water reservoir, (approximately 35 degrees Fahrenheit) and the lower supply cooling evaporator, (approximately 55 degrees Fahrenheit) inside the supply plenum. This will confirm that the unit is charged and cooling with refrigerant. Unplug the unit after temperature reductions have been confirmed.

Add five gallons of water to the water reservoir through the rear service opening and plug the SolCool in again. Set the Johnson Controls t-stat affixed to the compressor to 37 degrees to chill the water for about an two hours. You should have substantial ice build up around the water reservoir chiller manifold in 60-90 minutes. Replace the rear service panel and connect the yellow and red t-stat wires to activate the blowers and the water pump for final operation pre-check.

During correct operation the unit should be blowing approximately 1200 CFM at 60-65 degrees out of the supply plenum with no water leakage except for the condensate out of the condensate hole at the bottom, rear corner of the unit. If more water is flowing out of the unit, pull the lower rear service panel to check for any assembly leaks. If there are no leaks in the lower chamber, remove the large service panel and check for overspray falling between the skin of the unit and the water reservoir and the lower condensate pan on the water manifold/pad assembly and adjust accordingly.

After any unit pre-check and assembly adjustment(s) or tightening, disconnect the manifold supply hose at the connection to the water pad manifold and connect the t-stat wires to drain the unit and then disconnect the t-stat wires when the manifold supply hose stops draining water.

Follow the guidelines below after a successful pre-check.

Select a four foot by four foot install site that is flat and level, (a concrete surface is recommended) where the SolCool can be moved within approximately one foot of the wall that the supply and return, (if return is direct) will penetrate. Make sure the desired wall hole(s) are between the wall studs to avoid compromising wall support.

The following images depict a standard 100% interior air return install assembly in sections A, B & C, the 100% direct return transition wall sleeve and the 100% return stand that the unit sits on. The return sleeve and stand are made of 24 gauge galvanized steel with the stand frame made of 1.5 inch by 1.5 inch, 10 gauge galvanized angle steel. The SolCool requires a 100% interior air return install configuration in high humidity and or high heat situations.

SolCool 100% Return - Standard Install

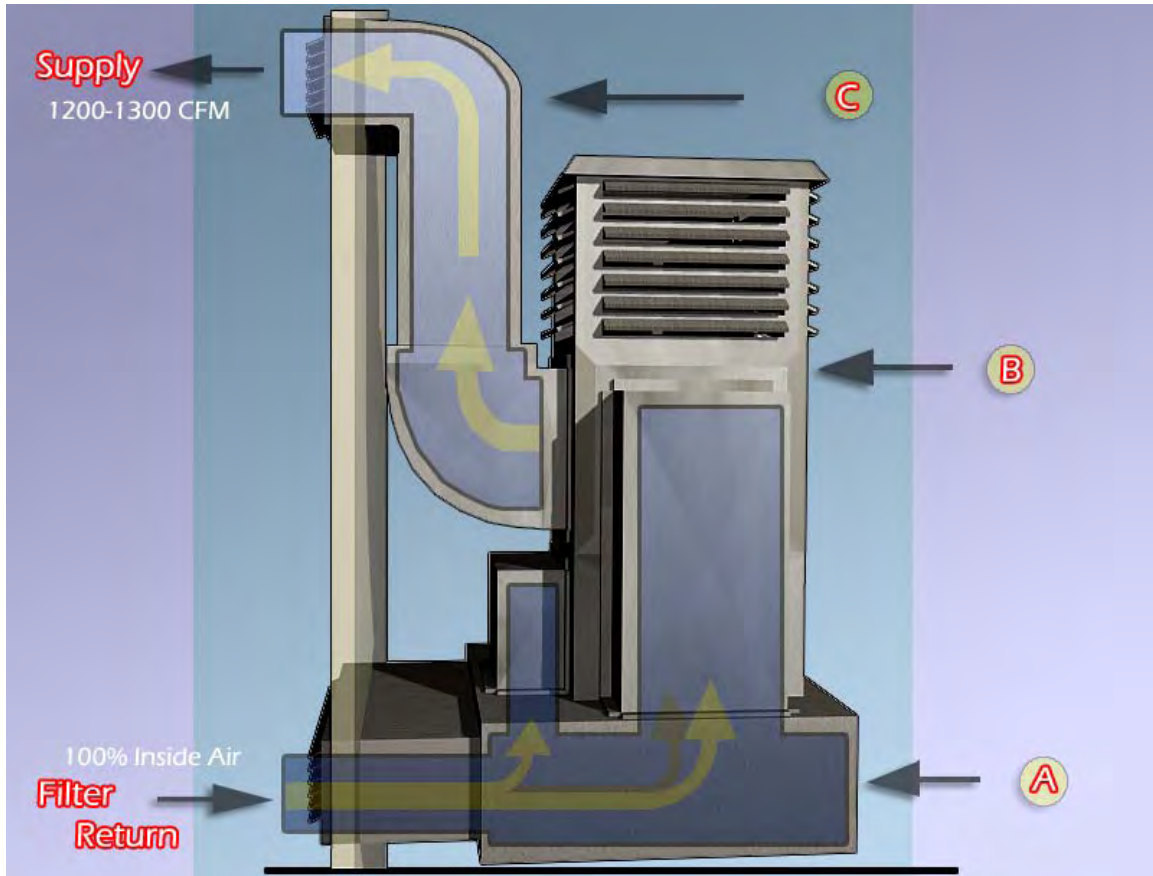

On the install assembly the letters depict the following:

“A” From the back you have the 100% return stand, the 100% return sleeve that attaches to the return stand and transitions from the outside to the inside and finally the 12x36 inch interior filter return register. If a support stud is a part of the 12 inch high x 36 inch wide wall hole, do not disturb the stud. Trim a stud slot in the return sleeve to avoid wall stud disturbance. Fill with foam insulation when return sleeve is set. If a ducted return system is used, the filtered return registers should be placed as far away from the supply register as practical with the insulated return ducting at the return stand connection a minimum of 12 inch inner diameter.

“B” From the back you have the SolCool Unit with the two 100% side return ducts that affix to the top of the return stand, the front 100% return duct that also affixes to the return stand and the 90 degree up flow supply plenum with the 14” round collar. The 100% return ducts and the up flow replace the standard return covers and supply plenum delivered on the unit and are critical in high humidity and or heat environments.

“C” From the 90 degree up flow supply plenum you have the three foot straight insulated duct to the 90 degree insulated duct, (Both 14 inch outer diameter, 12 inch inner diameter) to a 14 inch round collar/square wall box to a 14x14 inch, three-way interior supply register.

This direct high supply and low return configuration will maximize the SolCool’s effectiveness in a single large room of 800 -1200 square feet depending on the insulation of the structure and the BTU’s produced in the room. If the structure has several rooms and an attic, crawl space or false ceiling then filtered, ducted return is recommended for maximum cooling and circulation.

SolCool 100% Return - Standard Install

Fabricate the return stand per the engineering image attached.

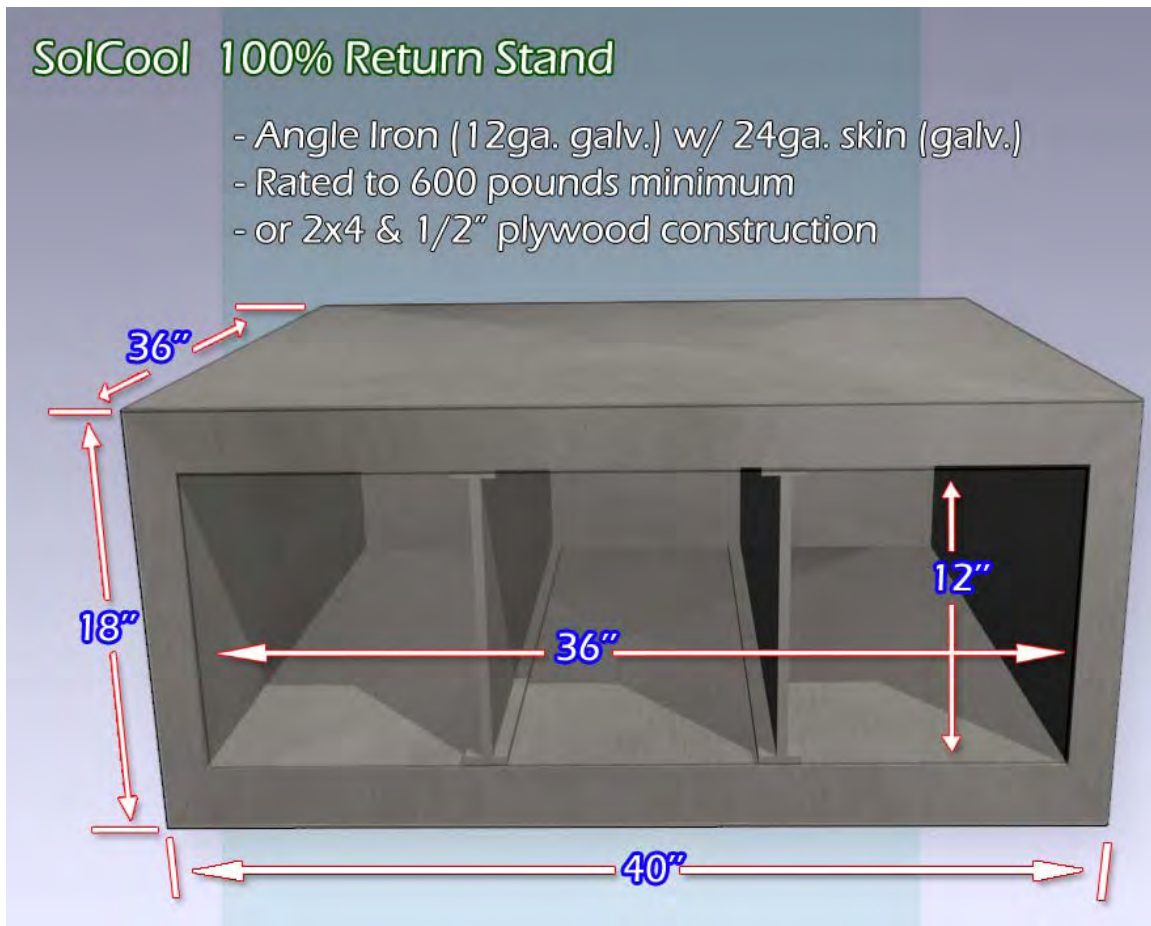

The return stand top would need to have three return holes and a condensate hole cut when the SolCool unit is centered on the return stand. After centering the unit, mark the condensate hole position and slide the SolCool to the side of the stand to cut out a 3 inch x 3 inch condensate hole in the stand. Recenter the SolCool on the stand, remove the three factory fan covers, (two side and one lower) and position the install the three 100% return ducts. Trace the three return ducts where they meet the stand, remove the ducts and calculate the duct inner diameter. Position and draw the duct inner diameter on the stand and cut out the return holes. Silicon and install the three 100% return ducts to the SolCool and then connect to the stand, image "B" with stainless, self tapping screws. The condensate assembly, (Watts PL-3500 quick connect male adapter with ¼ inch plastic tube at Lowe's) self threads with Teflon tape into the bottom of the SolCool unit condensate pan hole through the inside of the return stand condensate hole located in the rear corner of the SolCool. Drill a one-quarter inch condensate tube hole in the return stand where the condensate line is to run from the unit. Place an overflow assembly at the bottom of the return stand side where the condensate line runs and tie into the condensate line.

Once the SolCool unit is affixed to the stand, the return stand can be adjusted for final connection to the lower return sleeve or return ducting, (return sleeve length may need trim adjustment to coincide with the supply assembly) with self tapping screws and silver sealing tape, image "A".

SolCool 100% Return - Standard Install



The final supply assembly, image "C" may then be assembled. Silicon seal the joint between the replacement 90 degree supply up flow and the SolCool cabinet once the up flow is affixed to the unit. Drill a 1/8 inch hole in the lower center of the supply plenum/cabinet seam above the supply plenum and insert close to flush with the seam and silicon a one inch of piece of condensate tube that will drain the front evaporative coil condensate back into the water reservoir. Place wall supply hole between wall studs where possible.

The balance of the installation will consist of connecting the ¼ inch water line with shut off, hard wiring the 120 electric with shut off, structure thermostat positioning and installation, CoolGuard installation into the water reservoir and any solar, lighting or ceiling fan option installation.

More to follow.

Mark Walsh, Manager
SolCool One, LLC